

ST102

user manual

BLUEBIRD
version 1.0

This user manual is protected by copyright.

Copyright © 1995-2020 Bluebird Inc. All rights reserved.

Bluebird Inc. is the designer and manufacturer of Bluebird handheld mobiles.

This manual and the programs in this device are protected under international copyright laws, and may not be copied, distributed, translated, or removed by any means.

Registered Trademark



BLUEBIRD is an emerging global brand, striving to lead the market in performance and mobility. Their products represent reliability, innovation, and innovative technology. Bluebird is a registered trademark from the global brand of Bluebird Inc. and is copyright protected.

- Bluebird and stylized Bluebird Logo are registered trademarks and symbols of Bluebird Inc.
- Adobe® is a registered trademark of Adobe Systems Inc.
- All other trademarks and copyrights are the property of their respective owners.

User's Guidance

Device type	User's guidance
Class B Device (Household Information & Communication)	This device has qualified the electromagnetic wave suitable registration and can be used as a household device at a residential area as well as any other areas.
Type Registration	This wireless device may cause propagation interference, and so, it cannot be used for life-saving services.



Symbols

This manual uses the following symbols to indicate hazards and additional information.

Symbol	Name	Description
	Warning	Indicates situations that could cause injury to yourself or others.
	Caution	Indicates situations that could cause damage to your device or other equipment.
	Note	Indicates additional information that can help you get the most out of the device.



Please read this safety precaution information carefully. Failure to follow the information provided may result in fire, electric shock, or other property damage or bodily injuries.

Device



- Do not press the Power button on the device if the device is wet or do not touch adapter or power cord with wet hands. There is risk of electric shock.
- Do not use your device in an explosive danger zone.
- If your device becomes wet, do not put your device in heaters, microwaves, etc. to dry it. There is a risk of explosion or malfunction.



- Do not scratch the device's touchscreen. Use only your fingers or a compatible pen. Never use an actual pen, or any other sharp object on the touchscreen.
- Although this device is very sturdy, do not drop, hit, bend, or sit on it on purpose. It can be broken.
- Do not modify, take apart, or repair the device. Contact to your customer service center. Failure to do so will void your warranty.
- Do not attempt to modify your hardware or software. It may cause device malfunction and void your warranty.
- You may not be able to use this wireless device in basements, open fields, skyscrapers, or other places where the signal is weak.
- Backup the data and information from your device. Your data, such as ringtones, texts, and voice messages, may be erased during repairs or upgrades.
- Do not paint your device. It can damage your screen or your device's exterior.
- Avoid using or storing this device at extreme temperatures. This device is designed to work at temperatures between 0°C and 50°C (14°F and 122°F), and humidity level between 5% and 90%.



Environment



- Do not use the device while driving or operating heavy machinery. Doing so may result in death or serious injury.
- Do not use the device in locations with combustible goods. Doing so may result in an explosion.



- Do not use the device in dusty or hot locations. Doing so may damage the device.
- Do not expose your device to direct sunlight such as on the dashboard of a car for extended periods of time.
- Do not use the device in humid locations. Doing so may damage the device and void the warranty.
- Do not keep the device close to air conditioner vents. Corrosion within the device may occur due to condensation from changes in temperature.
- Do not allow children to play with the device.

Battery and Charging



- Improper battery use may cause fire, explosion, or other hazard.
- If the battery is removed due to impact, heat, submersion, or other damage, there is a risk of explosion. Keep away from children and animals.
- Do not allow the battery's contacts to touch things like necklaces, coins, or electric conductors. Do not give any impact with sharp objects. There is a risk of explosion.



- Use only the approved battery and charger. Using an incompatible battery or charger may cause device malfunction or other damage, such as fire.
- When you are not using the device for a long period, take out the battery and keep the device and the battery in a dry, cool place. Also, charge the battery at least once a year. If you keep it without charging for a long time, it may cause device malfunction.

Distraction



In some situations, using your device may distract you and cause serious injuries and damages. For example, avoid talking on the phone or texting while driving or riding a bicycle. It is strictly prohibited by law in some jurisdictions. If you cannot avoid using your device while driving, stop your vehicle or use hand-free kit.

Frequency Interference



- This wireless device may cause radio frequency interference, so use Airplane mode or turn off the device when prohibited.
- The device emits an electromagnetic fields. It may interfere with your medical devices.
- Do not place credit cards, phone cards, bankbook, and tickets next to the device. The magnetic field of the device can damage their magnetic strips.



ST102 Package Contents

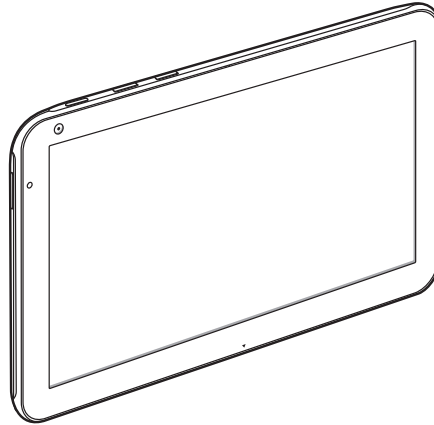

ST102 device

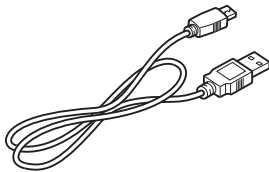

Micro USB cable

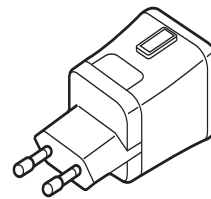

Power adapter



The images in this manual may not reflect the color and shape of the actual device. These illustrations are intended for descriptive purposes only.



Device Front

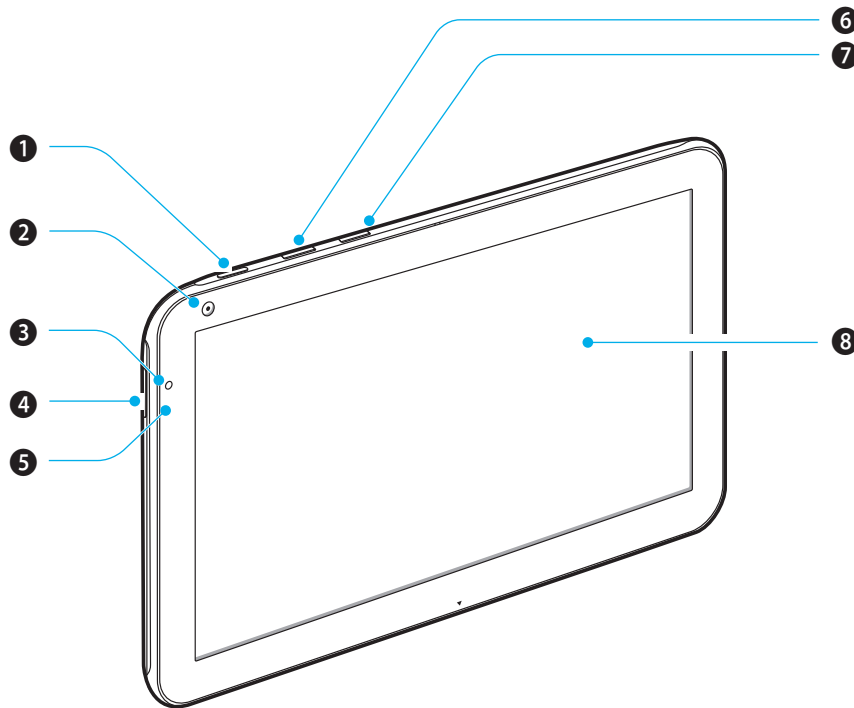

No.	Name	Description
1	Power button	Turns on the device.
2	Front camera	Captures pictures and video (2.0 megapixels).
3	Battery LED	Indicates the status of the battery. <ul style="list-style-type: none">• The battery LED turns red when the battery is charging.• The battery LED turns off when the battery is fully charged.• The battery LED blinks red at 1 second intervals when the battery has a problem, such as it being too hot or too cold.
4	Volume button	Turns the volume up or down.
5	Light sensor	Detects the ambient light to automatically adjust the brightness of the screen and the exposure of the camera.
6	SIM slot	Allows you to insert USIM (universal subscriber identity module) cards.
7	MicroSD slot	Allows you to insert removable memory cards (up to 64 GB).
8	Screen	Displays programs and acts as a multi-touch interface. <ul style="list-style-type: none">• The default resolution is 1280 × 800.



Device Back

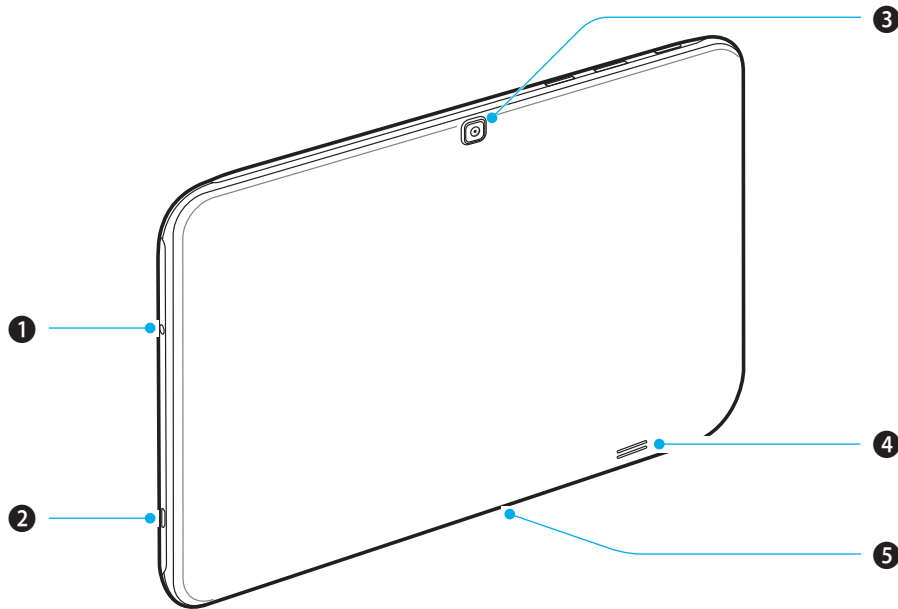

No.	Name	Description
1	Audio jack	Connects to the 3.5 mm adapter on headphones or computer speakers.
2	USB port	Connects to the power adapter to charge the device. Connects to USB devices, such as memory sticks, keyboards, and external hard drives.
3	Rear camera	Captures photos and video (8 megapixels).
4	Speaker	Emits sound.
5	Cradle connector	Connects the device to a cradle (optional).



Physical Characteristics

Dimensions (L x W x D)	255.4 x 172.4 x 12.2 mm
Weight	700 g
Display	10.1 inch, 1280 X 800 (WXGA)
Battery	Integrated Battery, 3.8 V, 6,000 mAh
Expansion slot	MicroSD 64 GB SDHC
SIM slot	1 Micro SIM
Audio	Loud Speaker, Microphone
Camera (optional)	Front: 2 megapixel Fixed Focus Rear: 8 megapixel Autofocus
GPS	A-GPS, GLONASS (for WWAN only)

Performance Characteristics

Processor	1.92 GHz Quad Core Processor
OS	Windows 10 IoT Enterprise
System memory	4 GB
Built-in storage	128 GB
Interface	Docking Connector, USB Type C (3.0) (OTG)



User Environment Characteristics

Operating temperature	0 °C to 50 °C (14 °F to 122 °F)
Storage temperature	-20 °C to 60 °C (-4 °F to 140 °F)
Humidity	90%, non-condensing

Communication

WWAN Radio (optional)	LTE, HSPA+/HSPA/UMTS, EDGE/GPRS
WLAN Radio	802.11 a/b/g/n/ac
WPAN Radio	Bluetooth 4.0 LE, Class 2

Accessories

Accessories	Power adapter, Adapter plug, Micro USB cable
-------------	--



Please ask your sales representative for the specifications not listed above or for the future upgradeable specifications.



The device does not turn on.

If your device does not turn on, the battery may be completely discharged. Charge the battery with an adapter for about 5-10 minutes, and your device should turn on.

The battery does not charge properly.

- Check the battery icon on your device to see if the device and the charging cable are connected.
- If the battery does not charge completely, it may be dead or defective. Replace the battery with a new one. (The warranty period for battery replacement is six months.)

The battery life got shorter.

When you use network data or peripheral device such as wireless LAN or Bluetooth that require more power, your device may use more battery than usual. If it happens for an extended period of time, your battery may be dead. Then replace it with a new battery.

I dropped the device in the water.

Turn off the device and take out the battery. Place the device and battery in a dry place. Let them dry completely for a considerable period of time, and then turn the device back on. If it does not turn back on, contact our service center.

My device gets too hot to touch.

It is normal for the device to warm up while it is receiving a poor signal, performing an intense workload, or charging. It should cool down if you stop using the device for a certain amount of time. If the problem continues, contact the manufacturer. It may result in a burst battery or fire.

How do I get the repair service?

You can contact your local sales representative or you can send the device via a delivery service to Bluebird's Korean headquarters. When sending the package, make sure you pay for the shipping fee in advance. When the repair is finished, Bluebird will cover the shipping cost.



FCC Cautions

This equipment has been tested and found to comply with the limits for a Class B digital device, pursuant to Part 15 of the FCC Rules. These limits are designed to provide reasonable protection against harmful interference in a residential installation. This equipment generates, uses and can radiate radio frequency energy and, if not installed and used in accordance with the instructions, may cause harmful interference to radio communications. However, there is no guarantee that interference will not occur in a particular installation. If this equipment does cause harmful interference to radio or television reception, which can be determined by turning the equipment off and on, the user is encouraged to try to correct the interference by one or more of the following measures:

- Reorient or relocate the receiving antenna.
- Increase the separation between the equipment and receiver.
- Connect the equipment into an outlet on a circuit different from that to which the receiver is connected.
- Consult the dealer or an experienced radio/TV technician for help.

Part 15.21 Information to user.

Any Changes or modifications not expressly approved by the party responsible for compliance could void the user's authority to operate the equipment.

Specific Absorption Rate (SAR) information:

This Mobile Phone meets the government's requirements for exposure to radio waves. The guidelines are based on standards that were developed by independent scientific organizations through periodic and thorough evaluation of scientific studies. The standards include a substantial safety margin designed to assure the safety of all persons regardless of age or health.

FCC RF Exposure Information and Statement The SAR limit of USA (FCC) is 1.6 W/kg averaged over one gram of tissue. This device was tested for typical body-worn operations with the back of the handset kept 10mm for body worn. To maintain compliance with FCC RF exposure requirements, use accessories that maintain a 10mm for body worn. The use of belt clips, holsters and similar accessories should not contain metallic components in its assembly. The use of accessories that do not satisfy these requirements may not comply with FCC RF exposure requirements, and should be avoided.

The highest reported SAR values for head and body are below:

Head: **XXXW/kg(1g)**; Body: **XXXW/kg(1g)** respectively.



Body-worn Operation

This device was tested for typical body-worn operations. To comply with RF exposure requirements, a minimum separation distance of 10mm for body worn must be maintained between the user's body and the handset, including the antenna. Third-party belt-clips, holsters, and similar accessories used by this device should not contain any metallic components. Body-worn accessories that do not meet these requirements may not comply with RF exposure requirements and should be avoided. Use only the supplied or an approved antenna.

FCC compliance information

This device complies with part 15 of the FCC Rules. Operation is subject to the following two conditions: (1) This device may not cause harmful interference, and (2) this device must accept any interference received, including interference that may cause undesired operation.



Manufacturer

Bluebird Inc.

Head Office: Samsung Saengmyung-irwonyeok Building C-3F, 115, Irwon-ro, Gangnam-gu, Seoul, Republic of Korea 06355

Factory: (SSang-young IT Twin tower-B 7~8F), 531, Dunchon-daero, Jungwon-gu, Seongnam-si, Gyeonggi-do, Korea, 13216

- Trade name: Bluebird Inc.
- Trade mark:



BLUEBIRD

Customer support

Before asking for after-sales service, please back up the data on the device. We do not back up data from the products sent to the Customer Service Center. Therefore, we assume no responsibility for loss/deletion of data.

Customer Service Center

#1103, Gplus Kolon Digital Tower 11F,
Digital-ro 26-gil 123, Guro-gu, Seoul, Republic of Korea(08390)

- Fax: +82-2-6499-2242
- Email: rma@bluebirdcorp.com
- Hours: 9:30 a.m. - 6:30 p.m. (GMT Time: +9 Hours)



The center is closed on Saturdays, Sundays, and Korean national holidays.

Registering for After-Sales Service

- We receive the products for our after-sales service through mail, delivery services and hand delivery only in principle.
- If you bought the product from a party other than Bluebird or an authorized Bluebird reseller, you need to register the product before using our after-sales service.
- Please enclose an evidence of purchase or the product receipt for our after-sales service.
- Please enclose your name, telephone number, address and details of the problem for a prompt service.
- You can ask for our after-sales service by contacting your authorized Bluebird dealer or the Customer Service Center in the head office.
- Do not intentionally damage the label on the product.



- A damaged label may result in a disadvantage to the customer.
- When you return the product to Bluebird for service, please put the product in a protective box.
- The warranty will not cover any damage which occurs during delivery. We advise you to use the box and protective cover supplied with the product.
- Make sure to deliver the product in a safe way. Bluebird assumes no responsibility for the loss of the product during delivery.

Charged services

- In the following cases, it will be charged when requesting for after-sales service.
 - Service request due to inappropriate use of the device by the customer
 - Loss of PIN number
 - Use of programs that might affect the program (over-clock, forceful changes in the input of the system, personal developments)
- Faults caused by the customer.
 - Defect due to inappropriate or careless use of the product (dropping, submersion under water, shock, damage, unreasonable operations, etc.)
 - Defect due to a repair or unauthorized technician
 - Defect caused intentionally or by the carelessness of the customer
 - Defect due to the use of fraudulent parts or components
- Other cases
 - Defect due to nature (damage caused by fire, wind, flooding, etc.)
 - Accessories are out of warranty (accessories like battery/charger/cable/adapter, etc. have a warranty of 6 months)
- Regulations for repairs after charged services
 - If the same fault occurs in the part that has been repaired within a 1 month (30 days), the part will be repaired free of charge.



No refunds will be offered in the following situations:

- The product seal has been removed (if applicable).
- The product has been damaged due to careless use by the customer or due to a natural disaster (floods, rain, fire, etc.).
- Loss of product or other components (manual, connecting cables, etc).
- DOA (Dead on Arrival) policy
If your product is DOA (Dead on Arrival), or has malfunction within 30 days of purchase (DOA period), the product will either be exchanged or provided with after-sales service.



Warranty certificate

Thank you for purchasing a product from Bluebird Inc.

- In case of accessories such as batteries, only those that match the sales list managed by the Customer Service Center will be eligible for customer service.
- A repair or an exchange of batteries that does not match the sales list of the Customer Service Center due to the carelessness of the customer will be fully charged.

Name of Product	Smart Tablet Computer
Name of Model	ST102
Date of Purchase	
Manufacture Number	
Place of Purchase	
Term of Guarantee	1 year from purchase

Warranty information

- Bluebird Inc. (hereinafter referred to as Bluebird) provides the warranty service for its products in compliance with the Bluebird's warranty program.
- Upon receiving a notification on a defect of its product within the range of warranty during the warranty period, Bluebird will repair or replace the defective product according to its warranty policy.
- If the defective product within the range of warranty is not repairable or replaceable, Bluebird shall refund the purchasing price within a designated period from the date of receiving a notice of defect.
- Bluebird assumes no responsibility for repairing, replacement or refund until it receives the defective product from the customer. The replacement shall be equivalent to a new product in the aspect of performance.
- Bluebird products may contain the recycled products, components or materials equivalent to new products in the aspect of performance.
- This warranty is applied to software products only when the programming commands are not executed. Bluebird does not guarantee interruption-free or error-free performance.



BLUEBIRD

BLUEBIRD CUSTOMER SERVICE

Operating Hours

Monday to Friday 9:30 A.M. - 6:30 P.M.
(GMT Time: +9 Hours)
The center is closed on Saturdays,
Sundays, and Korean national holidays.

Customer Service Center

#1103, Gplus Kolon Digital Tower 11F,
Digital-ro 26-gil 123, Guro-gu, Seoul,
Republic of Korea(08390)

Bluebird constantly strives to bring utmost satisfaction to all our customers.